

Single lift cylinder for easy maintenance

Closed fork tips

Quick lift pump as standard

AMX 10e: with electric lift

Energy-saving operation:  
no battery lift during lifting process



## AMX 10/10e

### Scissor Lift Truck (1000 kg)

The truck can be used as hand pallet truck, as well as, a lift table, marshalling table and/or a workbench.

- Steering wheels: Ø 170 mm with a choice of Nylon, rubber or Polyurethane tyres.
- Load wheels: Ø 82 mm with Nylon tyres.
- Lift height: up to 800 mm with additional support legs for stability.

- Lifting and lowering: manual or electro-hydraulic lift with 0.5 kW lift motor.
- Forks: robust, high-strength construction with closed fork tips.
- Battery (only for AMX 10e): 70Ah maintenance-free.
- AMX 10 with manual hydraulics: the load is raised to the optimum working

height with a few tiller movements. The scissor lift fork lift truck is stabilised by additional support legs whilst lifting.

- AMX 10e with electro-hydraulics: for frequent changes of working heights, the scissor lift truck with electric motor is recommended. The working height can be attained quickly using a push button.

# AMX 10/10e

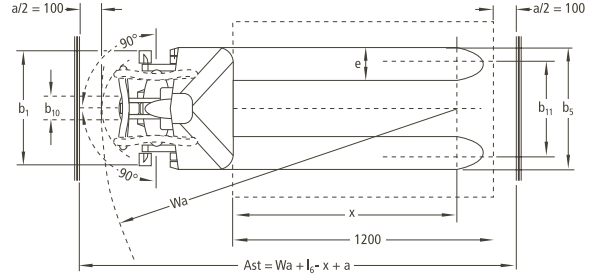
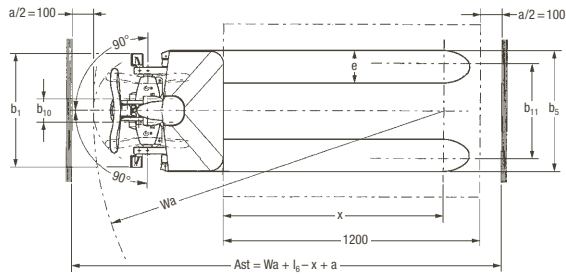
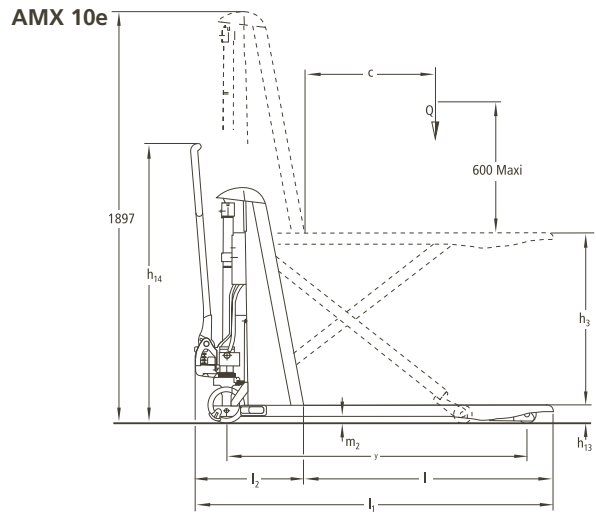
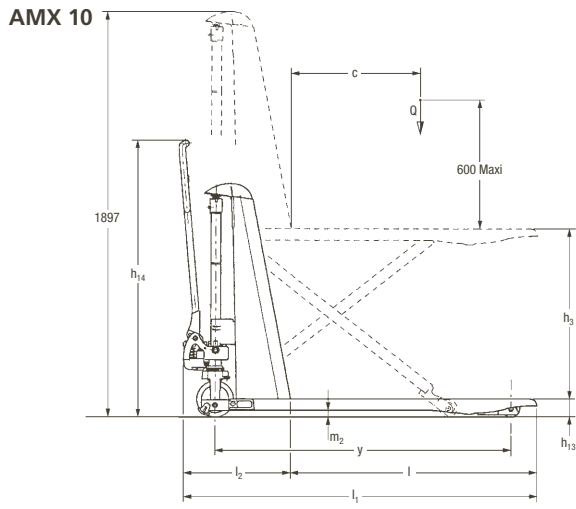

# Technical Data in line with VDI 2198 as at: 02/2009

Identification	1.1	Manufacturer (abbreviation)		Jungheinrich	Jungheinrich	1.1
	1.2	Manufacturer's type designation		<b>AMX 10e</b>	<b>AMX 10</b>	1.2
	1.3	Drive		electric	manual	1.3
	1.4	Operator type		hand <sup>2)</sup>	hand	1.4
	1.5	Load capacity / rated load	Q (t)	1	1	1.5
	1.6	Load centre distance	c (mm)	600	600	1.6
	1.8	Load distance, centre of drive axle to fork	x (mm)	1030	1030	1.8
	1.9	Wheelbase	y (mm)	1383	1383	1.9
	Weights	2.1	Service weight incl. battery (see line 6.5)	kg	199	157
2.2		Axle loading, laden front/rear	kg	443/752	406/751	2.2
2.3		Axle loading, unladen front/rear	kg	136/59	101/56	2.3
Wheels, Chassis	3.1	Tyres		N; C; V	N; C; V	3.1
	3.2	Tyre size, front	mm	170x44	170x44	3.2
	3.3	Tyre size, rear	mm	82x62	82x62	3.3
	3.4	Additional wheels (dimensions)	mm	82x62 <sup>1)</sup>	82x62 <sup>1)</sup>	3.4
	3.5	Wheels, number front rear (x = driven wheels)		2/2	2/2	3.5
	3.6	Tread, front	b <sub>10</sub> (mm)	109	109	3.6
	3.7	Tread, rear	b <sub>11</sub> (mm)	440	440	3.7
Basic Dimensions	4.4	Lift (standard mast)	h <sub>3</sub> (mm)	714	714	4.4
	4.5	Height, mast extended	h <sub>4</sub> (mm)	1897	1897	
	4.9	Height of tiller in drive position min./max.	h <sub>14</sub> (mm)	1299	1299	4.9
	4.15	Height, lowered	h <sub>13</sub> (mm)	86	86	4.15
	4.19	Overall length	l <sub>1</sub> (mm)	1650	1650	4.19
	4.20	Length to face of forks	l <sub>2</sub> (mm)	500	500	4.20
	4.21	Overall width	b <sub>1</sub> /b <sub>2</sub> (mm)	524/-	524/-	4.21
	4.22	Fork dimensions	s/e/l (mm)	53/150/1150	53/150/1150	4.22
	4.25	Distance between fork-arms	b <sub>5</sub> (mm)	560/680	560/680	4.25
	4.32	Ground clearance, centre of wheelbase	m <sub>2</sub> (mm)	30	30	4.32
	4.34	Aisle width for pallets 800x1200 lengthways	Ast (mm)	2005	2005	4.34
	4.35	Turning radius	Wa (mm)	1635	1635	4.35
Performance Data	5.2	Lift speed, laden/unladen	m/s	0.03/0.05	-	5.2
	5.3	Lowering speed, laden/unladen	m/s	0.13/0.05	0.11/0.04	5.3
Electric Engine	6.2	Lift motor rating at S <sub>3</sub> 15 %	kW	500 <sup>3)</sup>	-	6.2
	6.3	Battery acc. to DIN 43531 / 35/36 A, B, C, no		maintenance-free <sup>4)</sup>	-	6.3
	6.4	Battery voltage, nominal capacity K <sub>s</sub>	V/Ah	12/70	-	6.4
	6.5	Battery weight	kg	24	-	6.5

- 1) lateral support rollers  
 2) electric and manual lift  
 3) performance at S<sub>3</sub> 10 min. 7 %  
 4) integrated charger

# Make use of the advantages



## Easy handling

The smooth-running operating handle is ideally suitable for both left and right-handed operators. The special lowering valve facilitates loads being lowered particularly sensitively and proportioned.

## Effortless lifting and lowering

There is a choice of either manual hydraulic lift (AMX 10) or electro-hydraulic lift (AMX 10e) with a 0.5 kW lift motor. The pump aggregate has an integrated tank. The lowering valve integrated in the pump aggregate facilitates sensitive lowering via hand lever. The hydraulic system is protected against overloading with a pressure relief valve.



## Gentle on the back lift height

Jobs involving bending and heavy lifting soon affect health. The working height of the AMX 10/AMX 10e can be varied up to a height of 800 mm. This ensures back protecting operation. The scissor lift fork lift truck can also be equipped with lateral support rollers, so that moving with the forks raised is possible.



## Battery and charger (AMX 10e)

An inbuilt charger is fitted as standard. The maintenance-free battery (70 Ah) can be charged at any 13 Amp plug socket. The charger is automatically switched off when the charging process is completed.

## Jungheinrich UK Ltd.

Head Office:

Sherbourne House · Sherbourne Drive  
Tilbrook · Milton Keynes MK7 8HX  
Phone 01908 363100  
Fax 01908 363180

info@jungheinrich.co.uk  
www.jungheinrich.co.uk

Jungheinrich AG  
ISO 9001, ISO 14001  
Certification of Quality and  
Environment Management.



Jungheinrich trucks  
conform to the European  
Safety Requirements.



**JUNGHEINRICH**  
*Well worthwhile*